

Elektrim

THREE-PHASE INDUCTION MOTORS WITH SLIP-RING ROTOR FOR CONTINUOUS DUTY

OUTPUT AND DIMENSIONS TO IEC RECOMMENDATIONS

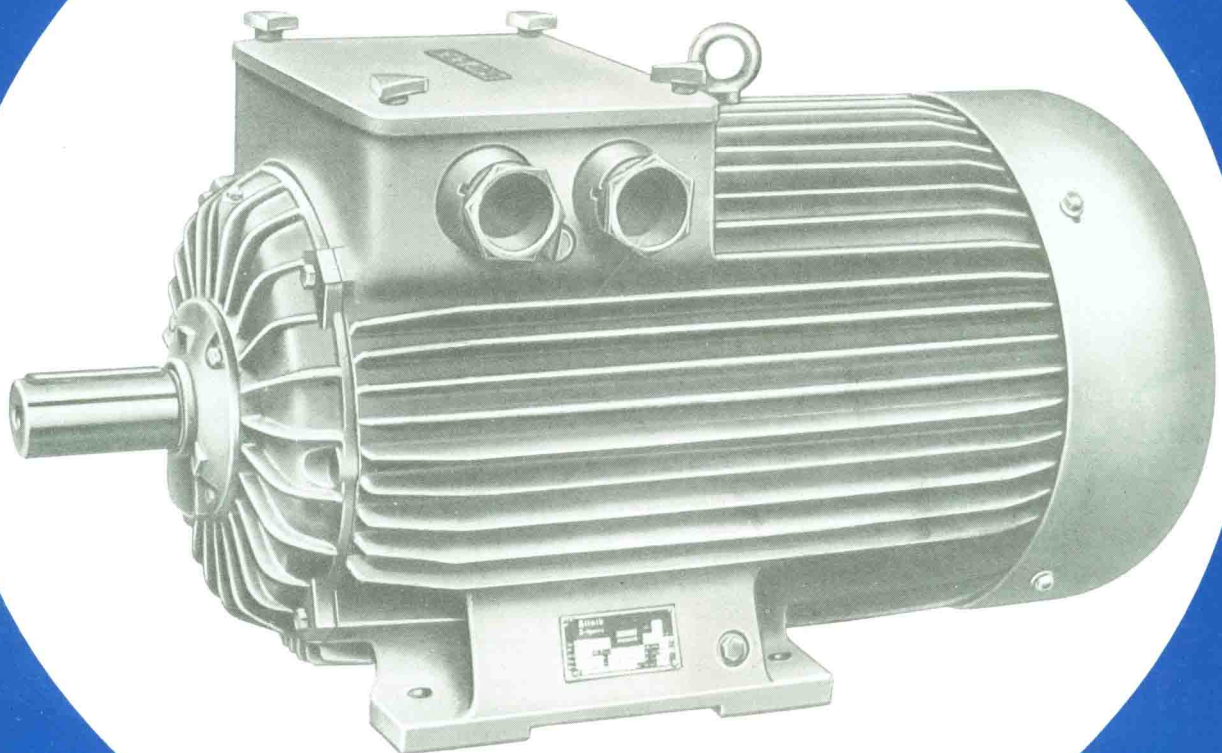

APPLICATION OF MOTORS

Motors are for continuous duty and are generally used in industry for driving various machines and equipments in continuous operation (S1) without frequent start - ups and reversals.

MOTOR CONSTRUCTION

The motor frame is made of ribbed iron casting. The terminal box is protected by means of a cover with a hole enabling easy access and observation of the sliding contact operation. Motor frame sizes 200-280 has the slip-ring head installed on the drive - end of the motor shaft. Dismounting and exchange of the brush holders may be carried out through the hole in the terminal box; dismantling of the bearing shield is not necessary.

Motors of frame sizes 315-400 has the slip-ring located on the motor non-drive end and they are accessible after removal of the protective covers.

Every motor is provided with an external fan on the non - drive end. All the motors of frame sizes 200-355 have the cooling system type, IC 01-41, while the motors of frame size 400 has the cooling system type IC 01-61 acc., to BN - 77/3010-13.

TYPE AND SIZE OF APPLIED BEARINGS

Grease should be refilled every 1000-1500 hours of motor operation or at least once every 6 months. After 2.5 to 3 years of operation, the grease in the bearing chambers should be exchanged. Old grease should be carefully removed and the bearings washed. The grease must be exchanged regardless of the time of operation. For the lubrication of the bearings LT 43 or LT 42 acc. to PN-72/C-96134, suitable for operation in the temperature range from -30 deg.C (243K) is used.

Equivalent of LT43 and LT42 greases:

Alvania 3-manufactured by SHELL

Baacon M-200-manufactured by ESSO

Energrease 1S3-manufactured by British Petroleum

TYPE AND SIZE OF APPLIED BEARINGS

FRAME SIZE	TYPE OF BEARING	
	DRIVE END "N"	NON - DRIVE END "P"
200	6312 / NU 312 /	6312
225	6313 / NU 313 /	6313
250	6315 / NU 315 /	6315
280	6317 / NU 317 /	6317
315	NU 320 P63C6S	6320 P6C6S // 6320 P63C6S //
355	NU 322 P63C6S	6322 P6C6S // 6322 P63C6S //
400	NU 324 P63C6S	6324 P6C6S

/ / bearings for special designs

// // apply to 4 pole motor only.

RATED POWER

Motor rated power is defined for continuous duty S1 at 50 Hz, coolant temperature 40 deg.C (313 K), temperature rise limit complying with the insulation classes B or F and mounting at the altitude up to 1000m above the sea level. For higher temperature and higher altitudes, admissible motor power output should be defined acc. to the data as follows:

STATOR WINDING

Motors with standard winding are intended for voltage UN=380V, 50Hz. Motors with special winding may be manufactured for voltage range 380V to 660V, 50HZ. On special request the production of motors for voltages lower than 380V but not lower than 220V may be agreed with the manufacturer.

INSULATION CLASS

Insulation class acc. to the PN/E-2050 complying with IEC/TC-2C/CO/3-V 1955 regulations, defines the max temperature permanently admissible, which does not damage the motor. Standard design motors of frame sizes 200-280 and 315-400 have stator and rotor windings of the class F.

Coolant temp. deg. C	40	45	50	55	60	65	70	75
Admissible power output in % of rated power for insulation class B	100	96	92	87	82	77	72	67
Admissible power output in % of rated power for insulation class F	—	—	—	—	100	96	92	87

Mounting altitude in meters above the sea level	1000	2000	3000	4000
Admissible power output in % of rated power	100%	94%	88%	82%

THERMAL PROTECTION OF WINDINGS

Motors of frame sizes 200-400 may be provided with thermistors on special request. Thermistors protect the stator winding against excessive heating in case of:

- motor overloading
- exceeding of the permissible number of on off switches
- single phase operation
- supply voltage drop
- high temperature and restricted cooling

Resistor leads are connected to the terminal strip in the terminal box. Rotor winding will not be provided with thermistors.

TERMINAL BOX

Terminal box in motors of frame sizes 200-280 is installed on top of the frame, which makes it possible to connect lead on the left or the right side. Terminal box contains the following:

- 3 terminals for stator winding (6 terminals on request)
- 3 terminals for rotor winding
- 2 terminal for thermistor circuit
- 1 terminal for zero lead or earth lead

Standard design motors of frame sizes 315-400 have two separate terminal boxes - one for the stator and one for the rotor - installed on the right side of the motor viewing from the drive end. On request, the terminal boxes may be situated on the motor left side. Stator terminal box contains 6 terminals for the stator winding, rotor terminal box contains 3 terminals.

To connect the thermistors, for the motors of frame sizes 200-280 cable glands type DVP 16 acc. to BN-72/3068-13 are provided.

CHARACTERISTIC OF SLIP RING HEADS AND BRUSHES

FRAME SIZE	HEAD		BRUSHES		
	Slip - ring diameter	Slip - ring material	Number off per motor	Dimensions / mm /	Brush material
200	140mm	Bronze or stainless steel	6	25 x 12.5 x 32	metallo-graphite
225	160mm			40 x 20 x 50	
250				40 x 20 x 40	
280	225mm		12		
315		40 x 20 x 40			
355					
400					

ORDERING OF MOTORS

while placing orders, the following informations should be given :

- motor type
- rated power
- type of duty
- rotational speed
- supply voltage
- current frequency
- mounting version
- degree of protection
- climatic version

TECHNICAL DATA OF SLIP-RING MOTORS FOR CONTINUOUS DUTY S1 VOLTAGE 380V, 415V

MOTOR TYPE	POWER OUTPUT		SPEED	STATOR CURRENT (AMPS)		COS ϕ	EFFICIENCY	MK MN	ROTOR		J	WT
	KW	HP		380V	415V				U2	I2		
			R.P.M.			--	%	--	V	A	KGM2	KG
4 poles ns = 1500rpm f=50hz												
SUG 200L4A	18.5	25	1445	39	36	0.84	86.5	3.8	210	56	0.34	285
SUG 200L4B	22	30	1445	46	43	0.84	87.0	3.6	235	59	0.36	300
SUG 225M4	30	40	1450	59	55	0.87	89.0	3.9	310	61	0.63	385
SUG 250M4A	37	50	1450	71	66	0.90	88.5	3.8	200	117	0.96	490
SUG 250M4B	45	60	1450	85	79	0.90	89.0	4.0	240	118	0.98	505
SUG 280S4	55	75	1450	103	96	0.91	89.5	3.2	240	144	1.70	650
SUG 280M4	75	100	1470	143	133	0.87	91.5	3.8	340	139	2.00	730
SUG 315S4A	90	125	1461	171	159	0.88	90.7	3.2	215	258	3.50	1020
SUG 315S4B	110	150	1468	207	193	0.88	91.9	3.5	271	248	4.10	1100
SUG 315M4	132	175	1472	243	226	0.88	92.8	3.8	327	245	4.70	1210
SUG 355S4	160	215	1477	294	273	0.89	92.8	3.4	342	284	6.80	1610
SUG 355M4	200	270	1481	360	335	0.90	93.8	3.8	437	276	8.10	1810
SUG 355L4	250	335	1484	451	419	0.91	94.9	4.4	521	298	13.10	1980
6 poles ns = 1000rpm f=50hz												
SUG 200L6	15	20	960	31	29	0.86	86.5	3.1	195	48	0.51	295
SUG 225M6A	18.5	25	965	36	33	0.87	88.5	3.3	215	54	0.85	370
SUG 225M6B	22	30	965	43	40	0.87	88.5	3.0	240	57	0.90	380
SUG 250M6A	30	40	965	60	56	0.85	89.0	3.0	150	126	1.40	495
SUG 250M6B	37	50	965	74	69	0.85	89.5	3.0	180	130	1.55	525
SUG 280S6	45	60	970	89	83	0.85	90.0	3.0	195	145	2.20	665
SUG 280M6	55	75	975	109	101	0.84	91.0	3.1	230	151	2.30	720
SUG 315S6	75	100	973	143	133	0.86	91.6	3.3	268	170	4.80	1000
SUG 315M6A	90	125	976	170	158	0.87	92.4	3.5	324	168	5.40	1100
SUG 315M6B	110	150	980	211	196	0.85	93.1	4.0	406	162	6.20	1180
SUG 355S6	132	175	981	247	230	0.87	93.4	3.2	374	213	8.20	1540
SUG 355M6	160	215	985	300	279	0.86	94.3	3.8	490	195	10.40	1740
SUG 355L6	200	270	986	375	349	0.88	94.8	4.1	620	201	17.00	1950
SUEM 400S6B	250	335	982	485	451	0.84	94.0	3.5	570	292	19.00	2050
3 poles ns = 750rpm f=50hz												
SUG 200L8	11	15	720	25	23	0.76	87.0	2.8	205	34	0.51	295
SUG 225M8A	15	20	720	33	31	0.80	86.0	2.4	175	54	0.85	370
SUG 225M8B	18.5	25	715	41	38	0.79	87.0	2.5	200	58	0.95	395
SUG 250M8A	22	30	720	48	45	0.79	88.0	2.6	135	103	1.40	505
SUG 250M8B	30	40	720	66	61	0.78	89.0	2.7	175	108	1.65	550
SUG 280S8	37	50	720	80	74	0.78	90.0	2.5	175	133	2.20	660
SUG 280M8	45	60	720	100	93	0.79	90.5	2.3	215	138	2.50	750
SUG 315S8	55	75	731	115	107	0.80	91.2	3.4	250	134	5.20	1095
SUG 315M8A	75	100	731	152	141	0.82	91.7	3.1	291	156	5.60	1150
SUG 315M8B	90	125	733	183	170	0.81	92.4	3.3	351	155	6.40	1200
SUG 355S8	110	150	735	218	203	0.82	93.4	2.9	350	188	10.90	1570
SUG 355M8A	132	175	735	261	243	0.82	93.8	3.1	413	191	12.40	1690
SUG 355M8B	160	215	737	313	291	0.82	94.6	3.2	504	189	14.80	1880
SUEM 400S8A	200	270	737	412	383	0.85	93.0	2.9	521	242	22.00	2100
SUEM 400S8B	250	335	738	472	439	0.86	93.5	2.8	595	260	25.60	2300
10 poles ns = 600rpm f=50hz												
SUG 355S10A	75	100	584	161	150	0.77	92.1	2.6	270	168	9.10	1490
SUG 355S10B	90	125	585	189	176	0.78	92.6	2.6	330	165	11.20	1650
SUG 355M10A	110	150	586	227	211	0.79	93.2	2.5	400	165	13.50	1870
SUG 355M10B	132	175	588	275	256	0.78	93.5	2.7	476	166	15.00	1980
SUEM 400M10A	160	215	589	346	322	0.79	93.5	2.9	485	268	25.80	2170
SUEM 400M10B	200	270	589	422	392	0.79	93.8	2.9	595	298	30.10	2350

Dimensioned drawing of slip ring motors Type SUG 200,225,250 & 280 for voltage 380v Delta (500v)

ASSEMBLY DIMENSIONS, (mm)

Motor type	No of poles	A	B	C	CA	H	HA	K	D	E	F	GA	DA
SUG 200L	4 - 8	318	305	133	400	200	35	19	55	110	16	59	55
SUG 225M	4 - 8	356	311	149	450	225	35	19	60	140	18	64	60
SUG 250M	4 - 8	406	349	168	480	250	40	24	70	140	20	74.5	65
SUG 280S	4 - 8	457	368	190	490	280	40	24	80	170	22	85	75
SUG 280M	4 - 8	457	419	190	490	280	40	24	80	170	22	85	75

Motor type	No of poles	AA	AB	AC	AD	BA	BB	HD	L	LC	Pg1	Pg2	-q
SUG 200L	4 - 8	80	400	460	220	100	380	480	940	1058	P42	P16	550
SUG 225M	4 - 8	85	445	505	240	110	400	540	1040	1190	P42	P16	600
SUG 250M	4 - 8	90	495	545	280	120	420	590	1130	1277	P76	P16	670
SUG 280S	4 - 8	100	560	610	305	140	470	675	1210	1358	P76	P16	670
SUG 280M	4 - 8	100	560	610	305	140	520	675	1260	1409	P76	P16	695

Motor type	No of poles	LA	M	Nj6	P	S	EA	FA	GC	AD1	HB	LB	T
SUKg 200L	4 - 8	16.5	350	300	400	18	110	16	59	275	560	900	5
SUKg 225M	4 - 8	18	400	350	450	18	140	18	64	300	630	975	5
SUKg 250M	4 - 8	19	500	450	550	18	140	18	69	330	680	1065	5
SUKg 280S	4 - 8	20	500	450	550	18	140	20	79.5	360	790	1125	5
SUKg 280M	4 - 8	20	500	450	550	18	140	20	79.5	360	790	1175	5

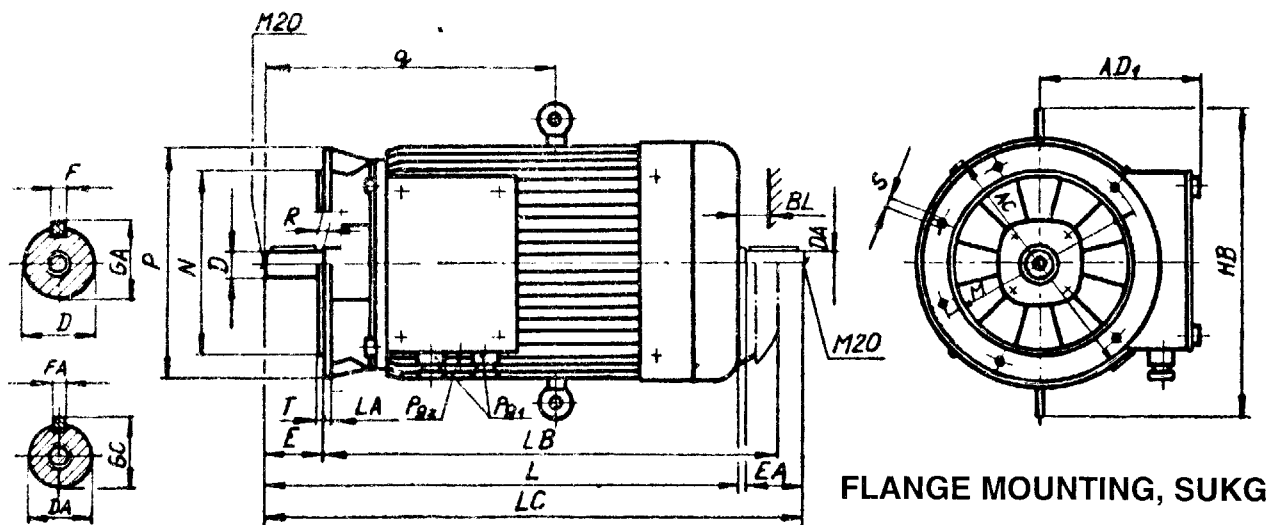
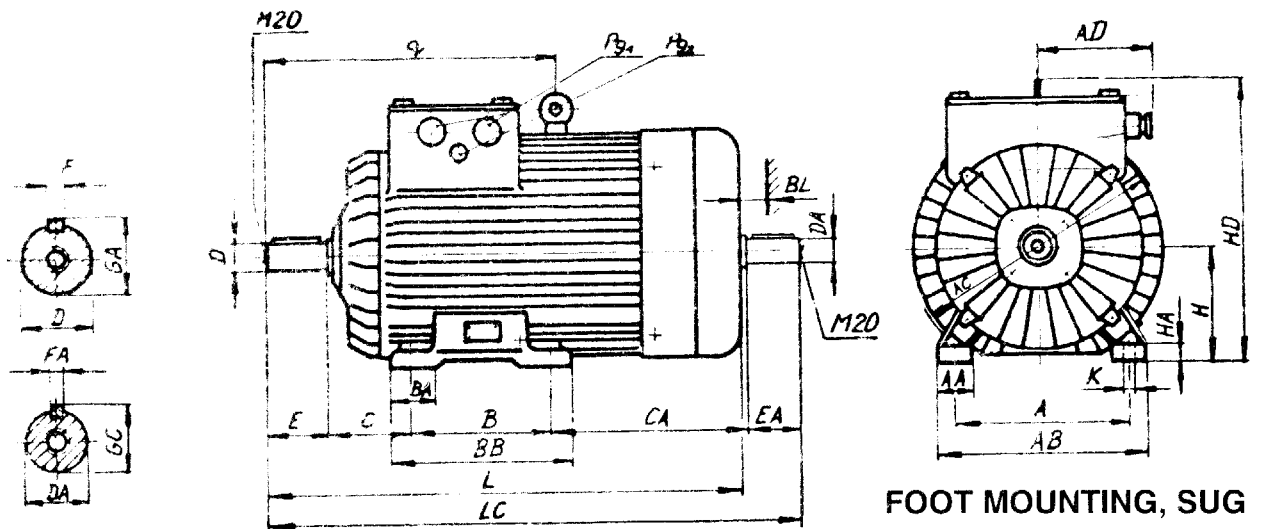

Dimensioned drawing of slipping motors Types SUG 315, 355 for voltage 380v Delta (500v)

Motor type	No of poles	A	AA	AB	AC	AD	AE	B	BA	BB	C	Dm6	E	F
SUG 315 S,SA,SB	4 - 8	508	134	640	693	585	347	406	150	500	216	80	170	22
SUG 315 M,MA,MB	4 - 8	508	134	640	693	585	347	457	150	500	216	80	170	22
SUG 355 S	4 - 12	610	158	720	764	620	382	500	170	600	254	100	210	28
SUG 355 M	4 - 12	610	158	720	764	620	382	560	205	730	254	100	210	28
SUG 355 L	4 - 12	610	158	720	764	620	382	630	170	730	254	100	210	28

Motor type	No of poles	GA	L	LE	LD	LH	H	HA	HC	HD	K	DB	DC
SUG 315 S,SA,SB	4 - 8	85	1402	175	414	506	315	45	662	749	28	54	44
SUG 315 M,MA,MB	4 - 8	85	1453	175	439	531	315	45	662	749	28	54	44
SUG 355 S	4 - 12	106	1067	215	499	564	355	50	737	848	28	54	44
SUG 355 M	4 - 12	106	1667	215	529	594	355	50	737	848	28	54	44
SUG 355 L	4 - 12	106	1737	215	529	594	355	50	737	848	28	54	44

Note:

In the free shaft neck of SUG 315 motors, there is a threaded centre hole 20mm acc. to PN-75/M-02497

In the free shaft neck of SUG 355 motors, there is a threaded centre hole 24mm acc. to PN-75/M-02497

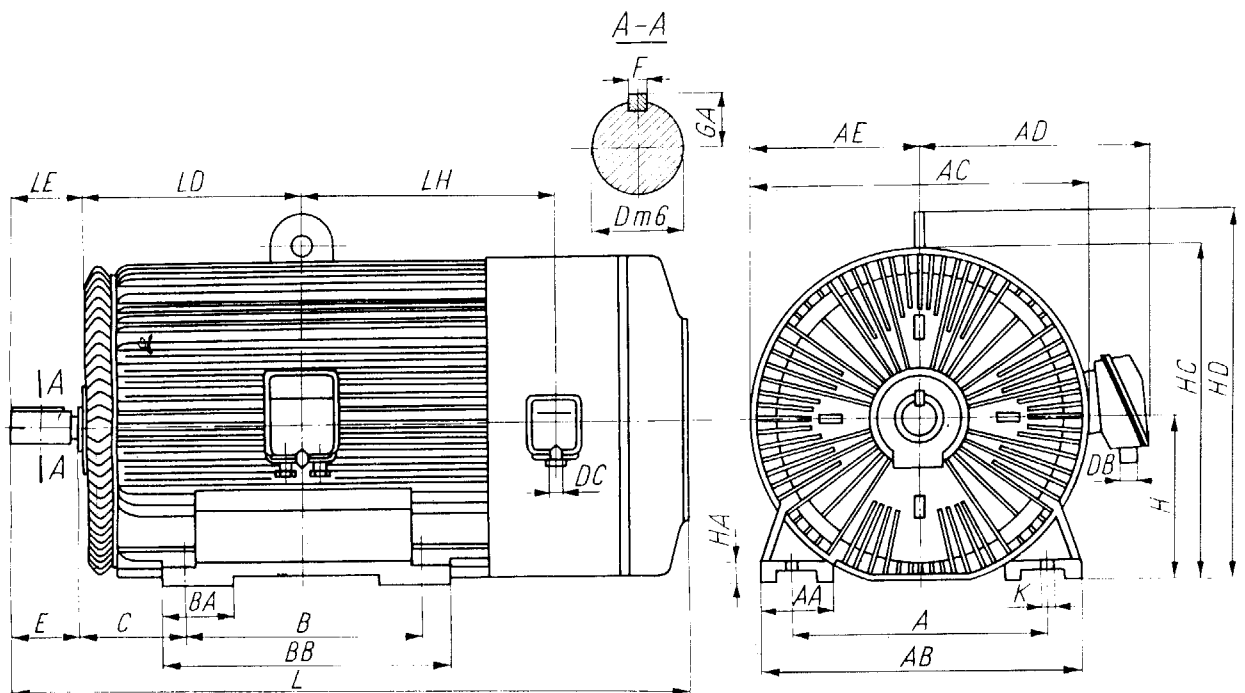

Dimensioned drawing of slipping motors Type SUem 400 for voltage 380v Delta (500v)

Motor type	No of poles	A	AA	AB	AC	AD	AE	B	BA	BB	C	Dm6	E	F
SUem 400 SB	6 - 12	686	155	850	790	590	395	560	175	700	280	110	210	28
SUem 400 MA, MB, MC	8 - 12	686	155	850	790	590	395	630	175	770	280	110	210	28

Motor type	No of poles	GA	L	LE	LD	LH	H	HA	HC	HD	K	DB	DC
SUem 400 SB	6 - 12	116	1715	220	550	620	400	50	1250	1340	35	54	44
SUem 400 MA, MB, MC	8 - 12	116	1785	220	585	655	400	50	1250	1340	35	54	44

Note :
The free shaft neck has a tapped centre 24mm.

